

Shuttlelift CD5500 Series

Product Guide

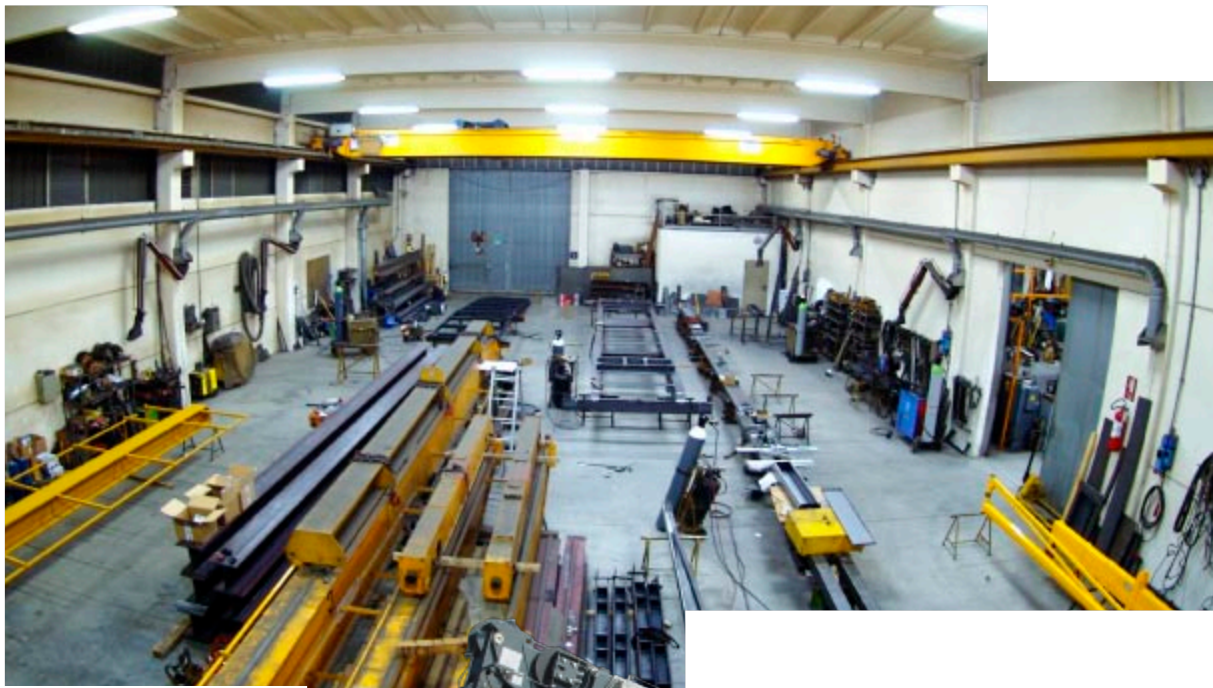

Features

- CD5540F: 13,6 t (15 USt) capacity three-section boom with 12,5 m (41 ft) outreach
- CD5560B: 16,3 t (18 USt) capacity four-section boom with 16,6 m (54 ft 6 in) outreach
- 4,6 m (15 ft) offsettable swingaway extension
- 9072 kg (20,000 lb) deck carrying capacity
- Available with diesel or dual fuel engine

Features

Outriggers

The CD5540F is equipped with single-position oblique style outriggers. The CD5560B comes equipped with two-position beam/jack style outriggers.



Cab

Both models come equipped with a **standard** open air cab shell with overhead safety glass.

An **optional** enclosed cab with hinged door, heater, and defroster is available.



Steering

Standard steering modes on the 5540F is two-wheel, four-wheel, and crab steer with an option for electronic self-alignment.

Standard steering modes on the 5560B include two-wheel, four-wheel, crab steer and electronic self-alignment



Cummins engine

The Cummins QSB 3,3 L, Tier III, diesel comes **standard** in both models.

Horsepower rating:

CD5540F: 63 kW (85 hp) at 2600 rpm.

CD5560B: 73,8 kW (99 hp) at 2600 rpm.



Boom

A 12,5 m (41 ft) main boom comes **standard** on the CD5540F. An **optional** fourth main boom section adds 3,4 m (11 ft) additional boom length.

The CD5560B comes **standard** with a 16,6 m (54 ft 6 in) main boom.

Contents

Specifications	4
CD5540F dimensions	7
CD5540F three-section boom working range	8
CD5540F four-section boom working range	9
CD5540F three-section boom load chart	10
CD5540F four-section boom load chart	11
CD5560B dimensions	12
CD5560B range diagram	13
CD5560B load chart	14
Symbols glossary	15

Specifications

Superstructure

Boom

CD5540F: 5,6 m – 12,5 m (18 ft 6 in – 41 ft 0 in) three-section full power boom.

Maximum tip height: 14,1 m (46 ft 3 in)

CD5560B: 5,6 m – 16,6 m (18 ft 6 in – 54 ft 6 in) four-section full power boom.

Maximum tip height: 19,0 m (62 ft 6 in)

*Optional boom

CD5540F: Manual fourth main boom fly section

Maximum tip height: 17,0 m (56 ft 3 in)

*Boom extension

4,6 m (15 ft) offsettable swingaway extension

Boom nose

CD5540F: Two sheave non-pivoting boom nose

CD5560B: Two sheave, -3-position (0°, + 40°, + 80°) pivoting boom nose for minimizing head space requirements. Lowers head height 0,4 m (15.9 in) when nose is pivoted fully forward.

Boom elevation

CD5540F: Single double acting hydraulic cylinder with integral holding valve.

CD5560B: Two double acting hydraulic cylinders with integral holding valve.

Elevation: 0° to 69° for the **CD5540F**
0° to 80° for the **CD5560B**

Anti-two block device

Standard anti-two block device, when activated, provides an audible warning to the crane operator and disengages all crane functions whose movement can cause two-blocking.



Load indicator (wireless LSI)

A simple effective and easy to use load indicating system used in conjunction with the anti-two block system to assist the operator in efficient operation of the unit within the limits of the load chart. The display panel displays the hook load and warns the operator when a preset load capacity is exceeded. The warning is by a flashing light on the display panel. In conjunction with the load display panel (receiver), there is a wireless transmitter and load sensing pin attached to the boom head that transmits the hook load to the display panel.



*Rated capacity limiter (wireless RCL)

Similar to the Load Indicator, but stops the telescope out and boom lift down function when a load limit is exceeded. Uses a similar display panel with the addition of displaying boom angle and boom length read outs on the panel.



*Load moment indicator (hardwired LMI)

Digital display of boom angle, boom length, boom radius, capacity, and allows for operator input to set the limits based on load chart. Displays color coded light bar and audible alarm with function cutout if load exceeds entered parameters.



Swing

Ball bearing swing circle with 360° continuous rotation. Hydraulic driven worm gear and pinion.

Maximum speed: **CD5540F:** 2.1 rpm

CD5560B: 2.5 rpm



Hydraulic system

Four section gear pump providing a system pressure of 241,3 bars (3500 psi)

Combined flow: 333,1 Lpm (88.0 gpm)

CD5540F: Six-section valve bank mounted in dash with direct mechanical linkage for low effort lever control.

CD5560B: Six-section valve bank chassis mounted; operated via dash mounted, pilot pressure hydraulic joysticks.

Return line filter with full flow by-pass protection and service indicator.

151,4 L (40 gal) hydraulic reservoir with sight level gauge and steel side plating to guard against side impact damage.

Specifications

Superstructure (continued)

Hoist specifications

Piston motor drive with spring applied / hyd. released brake. Equal speed power up and down.

Drum diameter: 0,25m (9.75 in)

Maximum hoist single line pull: 5443 kg (12,000 lb)

Maximum hoist single line speed:

CD5540F: 38,4 m/min (126 fpm)

CD5560B: 48,2 m/min (158 fpm)

Maximum permissible single line pull:

CD5540F: 3402 kg (7500 lb)
(12,7 mm [1/2 in])

CD5560B: 4082 kg (9000 lb)
(12,7 mm [1/2 in])

Rope length:

CD5540F:
(three-section boom) 73,0 m (240 ft)
(four-section boom) 88,4 m (290 ft)

CD5560B: 94,5 m (310 ft)

Carrier

Frame

High strength alloy steel constructed with integral outrigger housings; front and rear tie-down lugs. 75 ft² carrydeck size with 9072 kg (20,000 lb) carrying capacity. Deck coated with anti-skid treatment.

Outriggers

CD5540F: Front and rear oblique type beams at all four corners with integral holding valves. Outrigger pads form an integral part of the beam. Outrigger pad size 222 mm x 254 mm (8.75 in x 10 in).

Maximum pad load: 162 p.s.i.

CD5560B: Two-stage hydraulic telescoping beam with oblique type jack on all four corners, provides extended and down and retracted and down lifting capacities. Integral holding valves on both beam and jack. Outrigger pad size 222 mm x 254 mm (8.75 in x 10 in). Maximum pad load: 389 p.s.i.

Outrigger controls

CD5540F: Lever controls located on dash panel and operate the beams in pairs from side to side. Level bubble located inside operators compartment.

CD5560B: Two switch operation mounted on dash panel. One three- position rocker switch to select all beams / jacks, left beams / jacks only, or right beams / jacks only. Separate four- way toggle switch to activate beams out / in and jacks down / up. Level bubble indicator located inside operators compartment.

*Independent outrigger controls available as an option.

Standard engine (Tier III)

CD5540F: Cummins QSB 3,3 L turbo-charged diesel rated at 63,0 kW (85 bhp) at 2600 rpm.

CD5560B: Cummins QSB 3,3 L turbo-charged diesel rated at 73,8 kW (99 bhp) at 2600 rpm.

*Optional engine (0.7 EPA)

G.M. 4,3 L V-6 EFI dual fuel (gasoline / L.P.) rated @ 69,3 kW (93 bhp) @ 2500 rpm.

Operators control station

Frame mounted, open air style control station with cab shell includes all crane functions, driving controls, and overhead safety glass. Other standard equipment include a durable weather resistant seat with seat belt, hourmeter, sight level bubble, and fire extinguisher. The dash panel includes engine oil pressure gauge, engine water temperature gauge, fuel gauge, transmission low oil and high temperature warning lights, low battery warning light, and brake system low pressure warning light. The LSI (load indicator) receiver is mounted to the top of the dash.

*Operators control station enclosed

Includes the standard cab shell with the addition of front, right, and rear glass. Hinged full door with sliding glass.

Front windshield wiper, heater and defroster are included.

Specifications

Carrier (continued)



Fuel tank capacity

151,4 L (40 gal) all steel construction with steel side plate to guard against side impact.



Electrical system

One 12V maintenance free battery, 820CCA @ 0°. 63 amp alternator.

I-0-I Drive

4 x 2 – Front axle drive with planetary hubs and limited slip differential.



Steer

CD5540F: Two-wheel, four-wheel, and crab steer
CD5560B: Two-wheel, four-wheel, and crab steer with electric self alignment.

Outside turning radius:

CD5540F/CD5560B:

Two wheel steer: 6,55 m (21 ft 6 in)

Four wheel steer: 3,76 m (12 ft 4 in)



Transmission

CD5540F: I.T.L. synchromesh four-speeds forward and reverse.

CD5560B: I.T.L. powershift four-speeds forward and reverse. Stalk mounted shifter on left side of steering column.



Tires

385/65R 22.5 radial traction tread pneumatic.



Brakes

Hydraulic actuated internal wet-disc service brakes acting on all four wheels. A dash mounted toggle switch activates the dry disc parking brake on the transmission output yoke with a dash warning light.



Suspension

Front: Rigid mounted to frame.

Rear: Provides 1.5° oscillation for use on semi-rough terrain. Axle lock-out must be engaged (locked) whenever picking on rubber or traveling in the crab steer mode. A warning light indicates when the axle lock-outs are engaged.

*Optional 4° oscillation.



Lights

Recessed mounted, includes head, tail, rear work, stop, and turn signals.



Maximum speed

CD5540F: 23,3 km/h (14.5 mph)

CD5560B: 33,8 km/h (21.0 mph)



Gradeability (theoretical)

CD5540F: 73%....no load

41%.... 9072 kg (20,000 lb) load

CD5560B: 68%....no load

40%.... 9072 kg (20,000 lb) load

Gross vehicle weight (G.V.W)

CD5540F: 12 742 kg (28,090 lb) three-section boom

12 966 kg (28,584 lb) four-section boom

CD5560B: 14 769 kg (32,560 lb)

Miscellaneous standard equipment

Two sheave, “Quick Reeve” style hookblock; CD5540F:

13,6 t (15.0 USt); CD5560B: 16,3 t (18.0 USt).

Back-up alarm

Lifting and tie down lugs

Outrigger motion alarm

Dimensions

CD5540F

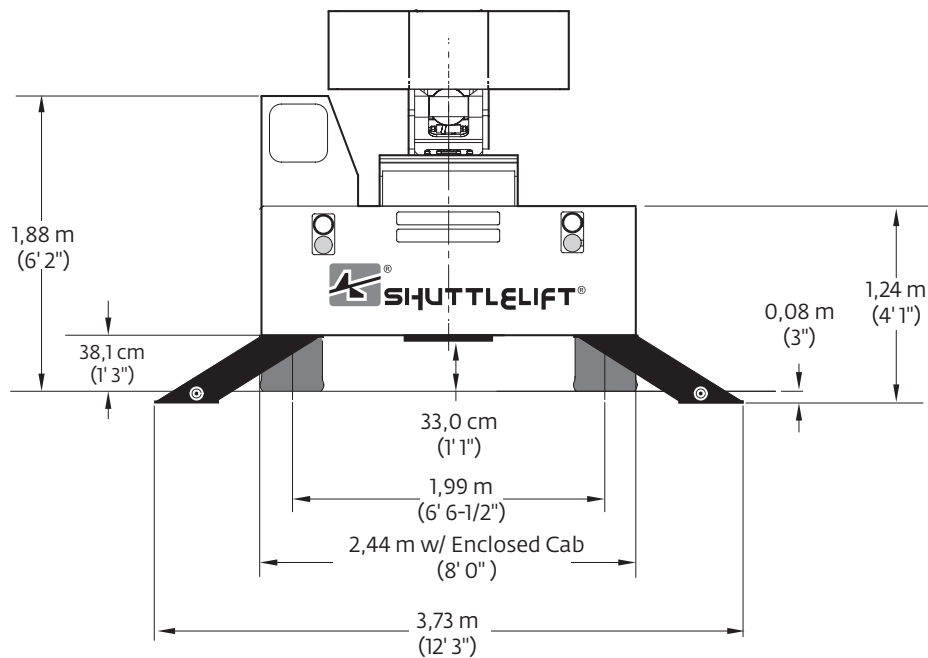
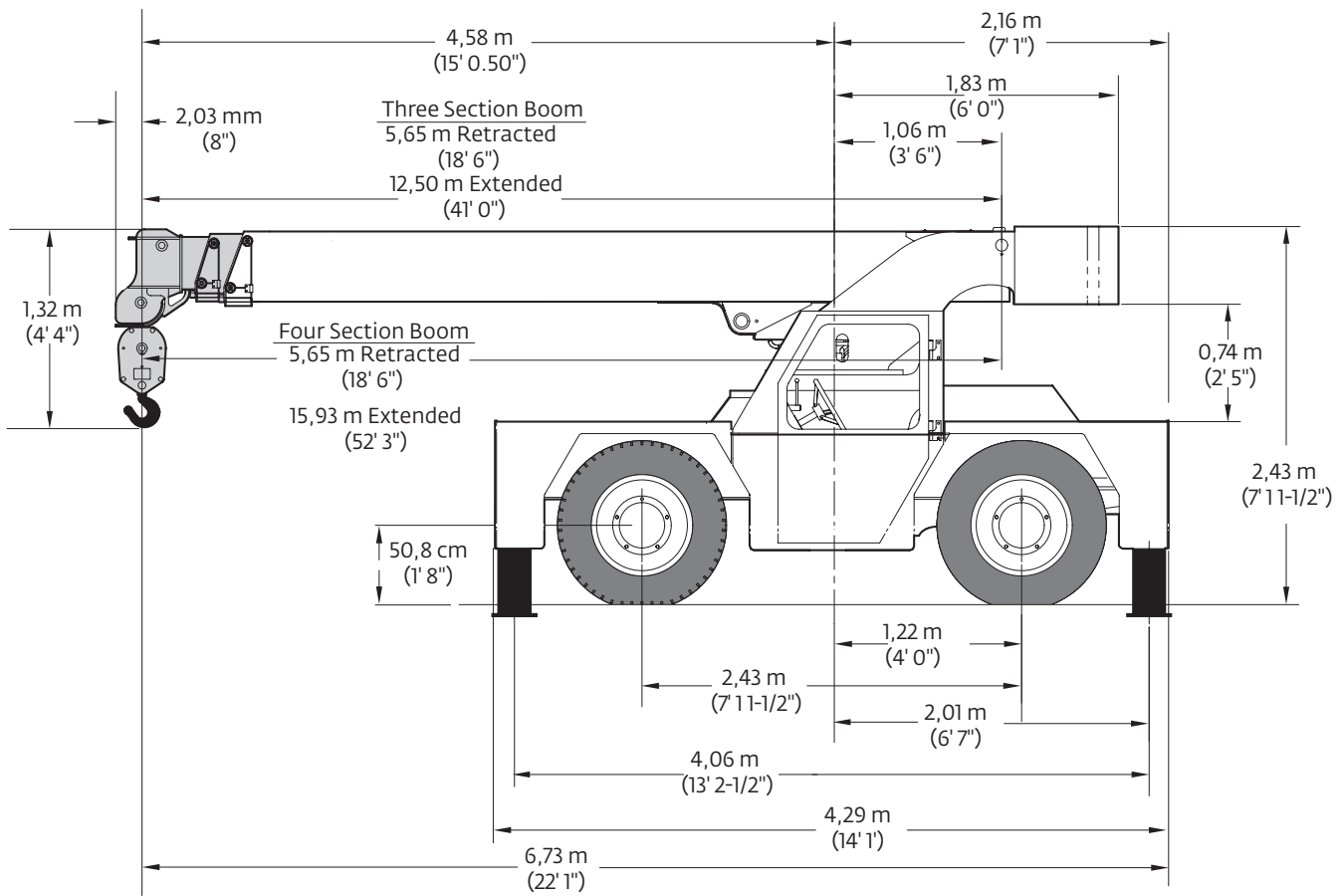

THIS CHART IS ONLY A GUIDE AND SHOULD NOT BE USED TO OPERATE THE CRANE.

The individual crane's load chart, operating instructions and other instructional plates must be read and understood prior to operating the crane.

Range diagram

CD5540F (Three-section boom)

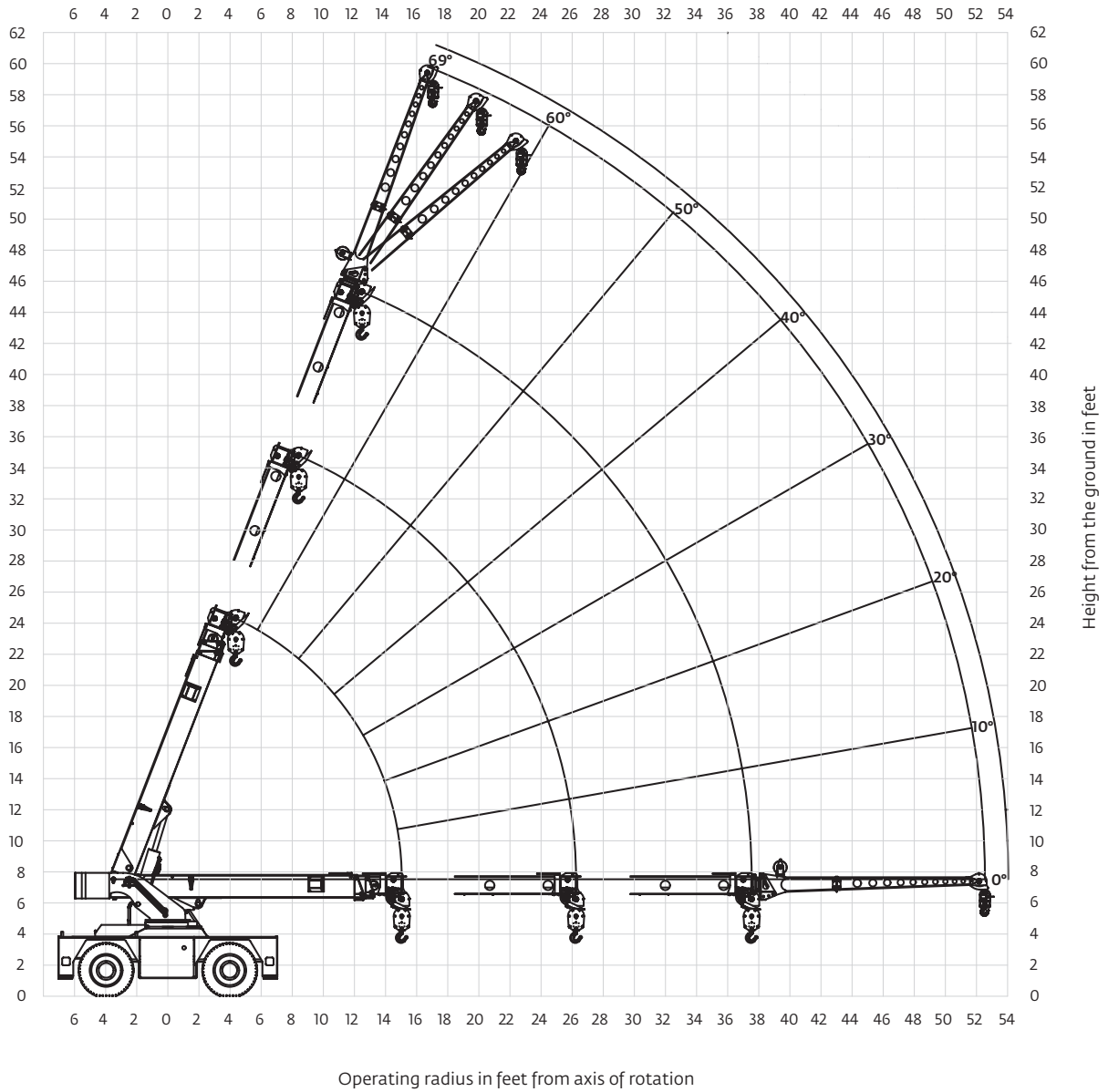

*THIS CHART IS ONLY A GUIDE AND SHOULD NOT BE USED TO OPERATE THE CRANE.
The individual crane's load chart, operating instructions and other instructional plates must be read and understood prior to operating the crane.*

Range diagram

CD5540F (Four-section boom)

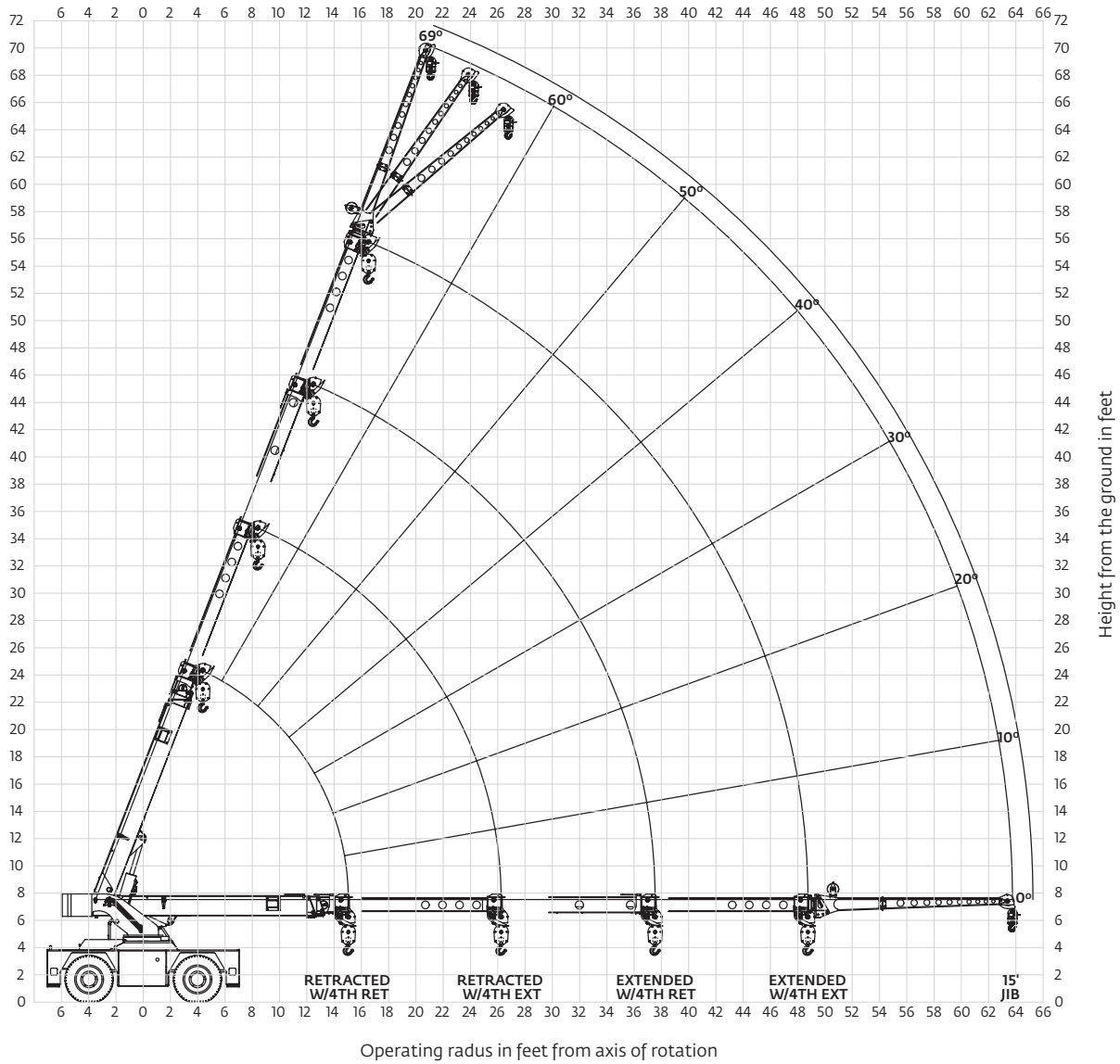

THIS CHART IS ONLY A GUIDE AND SHOULD NOT BE USED TO OPERATE THE CRANE.

The individual crane's load chart, operating instructions and other instructional plates must be read and understood prior to operating the crane.

Load chart

CD5540F (Three-section boom)

	RADIUS (ft)	ON OUTRIGGERS (lb)		ON RUBBER (lb)	
		F/R	360°	F/R	360°
MAIN BOOM	6.0	30,000	30,000	17,000	17,000
	8.0	26,200	26,200	13,500	14,600
	10.0	22,300	22,300	10,700	10,880
	12.0	18,600	18,600	8710	8100
	14.0	14,800	14,800	7210	6000
	15.0	13,000	13,000	6600	5250
	16.0	12,200	12,200	6060	4760
	18.0	10,800	10,800	5120	3900
	20.0	9630	9180	4370	3190
	22.0	8640	7480	3710	2660
	24.0	7790	6210	3070	2200
	26.0	7040	5310	2620	1820
	28.0	6420	4740	2260	1530
	30.0	5700	4290	1990	1320
	32.0	5060	3920	1790	1160
	34.0	4510	3580	1610	1040
	36.0	4020	3260	1460	930
37.5	3700	3060	1370	860	
JIB	40.0	3480	2860	1270	800
	42.0	3310	2700	1190	740
	44.0	3130	2560	1120	690
	46.0	2960	2410	1040	640
	48.8	2710	2210	930	570
	52.5	2390	1940	790	480

MAIN BOOM ANGLE (deg)	JIB STRUCTURAL CAPACITIES (lb)		
	0°	15°	30°
69	6000	3900	2800
65	5000	3500	2550
60	4300	3150	2350
55	3800	2850	2200
50	3400	2600	2100
45	3050	2400	2000
40	2800	2250	1950
35	2600	2150	1900
30	2400	2080	1850
25	2300	2050	-
20	2200	2000	-
15	2100	1950	-
10	2050	-	-
5	2020	-	-
0	2000	-	-

NOTES:

JIB CAPACITY IS LIMITED BY BOTH STRUCTURAL CAPACITY CHART AND MAIN CAPACITY CHART.

SHADED AREAS ARE GOVERNED BY STRUCTURAL STRENGTH, DO NOT RELY ON TIPPING.

OPERATION OF THIS EQUIPMENT IN EXCESS OF RATING CHARTS AND DISREGARD OF INSTRUCTIONS IS DANGEROUS AND VOIDS WARRANTY.

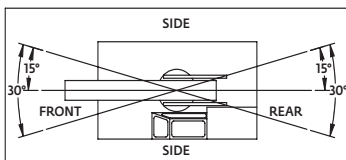

REDUCTION CHART		
	FROM MAIN BOOM RATINGS	FROM JIB RATINGS
MAIN BLOCK	210 lb	N/A
HOOK & BALL	100 lb	100 lb
JIB, STOWED	0 lb	N/A
JIB, DEPLOYED	700 lb	0 lb

RIGGING CHART	
1-PART 0 - 7500 lb	4-PART 0 - 30,000 lb
WIRE ROPE: 1/2 in diameter Minimum breaking strength 26,250 lb	

1) The rated loads are the maximum lifting capacities as determined by operating radius only. Any combination of boom lengths and angles may be used to obtain operating radius. The operating radius is the horizontal distance from a projection of the axis of rotation to the supporting surface, before loading, to the center of vertical hoist line or tackle with load applied.

2) The rated loads shown on outriggers do not exceed 85% of actual tipping. The rated loads shown on rubber do not exceed 75% of actual tipping. These ratings are based on freely suspended loads with the crane leveled, standing on a firm, uniform supporting surface. Practical working loads depend on supporting surface, operating radius and other factors affecting stability. Hazardous surroundings, climatic conditions, experience of operator and proper training must be taken into account by the operator.

3) The weights of all load handling devices, such as hooks, hook blocks, slings, etc., except the hoist rope, shall be considered as part of the load. See reduction chart.

4) Ratings on outriggers are with outriggers fully extended.

5) Ratings on rubber depend on tire capacity, condition of tires and proper inflation pressure (120 psi). Loads on rubber may be transported at a maximum speed of 2.5 mph on a smooth, hard, level surface with the boom retracted to the shortest length possible and centered over the front.

6) For operating radius not shown, use load rating of next larger radius.

7) The maximum combined total boom and deck load is 16,000 lb. The maximum deck load only is 20,000 lb.

8) Do not induce any external side loads to boom or jib.

1302442

THIS CHART IS ONLY A GUIDE AND SHOULD NOT BE USED TO OPERATE THE CRANE.

The individual crane's load chart, operating instructions and other instructional plates must be read and understood prior to operating the crane.

CD5540F (Four-section boom)

RADIUS (ft)	4TH RETRACTED				RADIUS (ft)	4TH EXTENDED			
	ON OUTRIGGERS (lb)		ON RUBBER (lb)			ON OUTRIGGERS (lb)		ON RUBBER (lb)	
	F/R	360°	F/R	360°		F/R	360°	F/R	360°
6.0	30,000	30,000	17,000	17,000	6.0	-	-	-	-
8.0	26,200	26,200	13,500	14,600	8.0	11,000	11,000	11,000	11,000
10.0	22,300	22,300	10,700	11,000	10.0	10,700	10,700	10,700	10,700
12.0	18,600	18,600	8710	7650	12.0	9250	9250	9250	9250
14.0	14,800	14,800	7210	5480	14.0	8290	8390	7760	7500
15.0	13,000	13,000	6600	4890	15.0	8200	8200	7150	6080
16.0	12,200	12,200	6060	4500	16.0	8110	8110	6610	5510
18.0	10,800	10,600	4950	3750	18.0	7950	7950	5680	4500
20.0	9630	8630	3980	3080	20.0	7820	7820	4730	3560
22.0	8640	7350	3230	2460	22.0	7710	7710	3980	3000
24.0	7790	6460	2720	1990	24.0	7630	7270	3410	2520
26.0	6800	5700	2360	1610	26.0	7100	6330	2940	2150
28.0	5820	5040	2100	1410	28.0	6590	5420	2550	1840
30.0	5020	4420	1880	1220	30.0	5710	4760	2190	1580
32.0	4400	3950	1650	1070	32.0	5180	4080	1880	1360
34.0	3930	3570	1460	920	34.0	4680	3570	1600	1160
36.0	3510	3190	1280	770	36.0	4250	3190	1370	990
37.5	3210	2890	1180	680	37.5	3830	2970	1240	880
40.0	2950	2600	1070	610	40.0	3400	2700	1070	740
42.0	2760	2430	970	550	42.0	3150	2490	960	630
44.0	2590	2250	890	500	44.0	2890	2300	870	540
46.0	2430	2090	800	450	46.0	2630	2130	790	470
48.8	2240	1850	680	380	48.8	2320	1930	710	370
52.5	2030	1480	500	290	52.5	2070	1710	590	280
58.0	-	-	-	-	58.0	1720	1380	420	170
63.8	-	-	-	-	63.8	1330	1020	230	60

MAIN BOOM ANGLE (deg)	JIB STRUCTURAL CAPACITIES (lb)					
	4TH RETRACTED			4TH EXTENDED		
	0°	15°	30°	0°	15°	30°
69	6000	3900	2800	5180	3900	2800
65	5000	3500	2550	4970	3500	2550
60	4300	3150	2350	4300	3150	2350
55	3800	2850	2200	3800	2850	2200
50	3400	2600	2100	3400	2600	2100
45	3050	2400	2000	3050	2400	2000
40	2800	2250	1950	2800	2250	1950
35	2600	2150	1900	2600	2150	1900
30	2400	2080	1850	2400	2080	1850
25	2300	2050	-	2300	2050	-
20	2200	2000	-	2200	2000	-
15	2100	1950	-	2100	1950	-
10	2050	-	-	2050	-	-
5	2020	-	-	2020	-	-
0	2000	-	-	2000	-	-

NOTES:

JIB CAPACITY IS LIMITED BY BOTH STRUCTURAL CAPACITY CHART AND MAIN CAPACITY CHART.

SHADED AREAS ARE GOVERNED BY STRUCTURAL STRENGTH, DO NOT RELY ON TIPPING.

OPERATION OF THIS EQUIPMENT IN EXCESS OF RATING CHARTS AND DISREGARD OF INSTRUCTIONS IS DANGEROUS AND VOIDS WARRANTY.

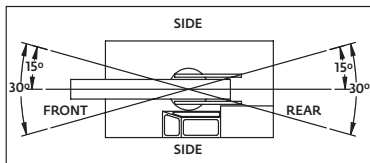

REDUCTION CHART		
	FROM MAIN BOOM RATINGS	FROM JIB RATINGS
MAIN BLOCK	210 lb	N/A
HOOK & BALL	100 lb	100 lb
JIB, STOWED	0 lb	N/A
JIB, DEPLOYED	700 lb	0 lb

RIGGING CHART	
<p>1-PART 0 - 7500 lb</p>	<p>4-PART 0 - 30,000 lb</p>
<p>WIRE ROPE: 1/2 inch diameter Min. breaking strength 26,250 lb</p>	

- The rated loads are the maximum lifting capacities as determined by operating radius only. Any combination of boom lengths and angles may be used to obtain operating radius. The operating radius is the horizontal distance from a projection of the axis of rotation to the supporting surface, before loading, to the center of vertical hoist line or tackle with load applied.
- The rated loads shown on outriggers do not exceed 85% of actual tipping. The rated loads shown on rubber do not exceed 75% of actual tipping. These ratings are based on freely suspended loads with the crane leveled, standing on a firm, uniform supporting surface. Practical working loads depend on supporting surface, operating radius and other factors affecting stability. Hazardous surroundings, climatic conditions, experience of operator and proper training must be taken into account by the operator.
- The weights of all load handling devices, such as hooks, hook blocks, slings, etc., except the hoist rope, shall be considered as part of the load. See reduction chart.
- Ratings on outriggers are with outriggers fully extended.
- Ratings on rubber depend on tire capacity, condition of tires and proper inflation pressure (120 psi). Loads on rubber may be transported at a maximum speed of 2.5 mph on a smooth, hard, level surface with the boom retracted to the shortest length possible and centered over the front.
- For operating radius not shown, use load rating of next larger radius.
- The maximum combined total boom and deck load is 16,000 lb. The maximum deck load only is 20,000 lb.
- Do not induce any external side loads to boom or jib.

1302395

THIS CHART IS ONLY A GUIDE AND SHOULD NOT BE USED TO OPERATE THE CRANE.

The individual crane's load chart, operating instructions and other instructional plates must be read and understood prior to operating the crane.

Dimensions

CD5560B

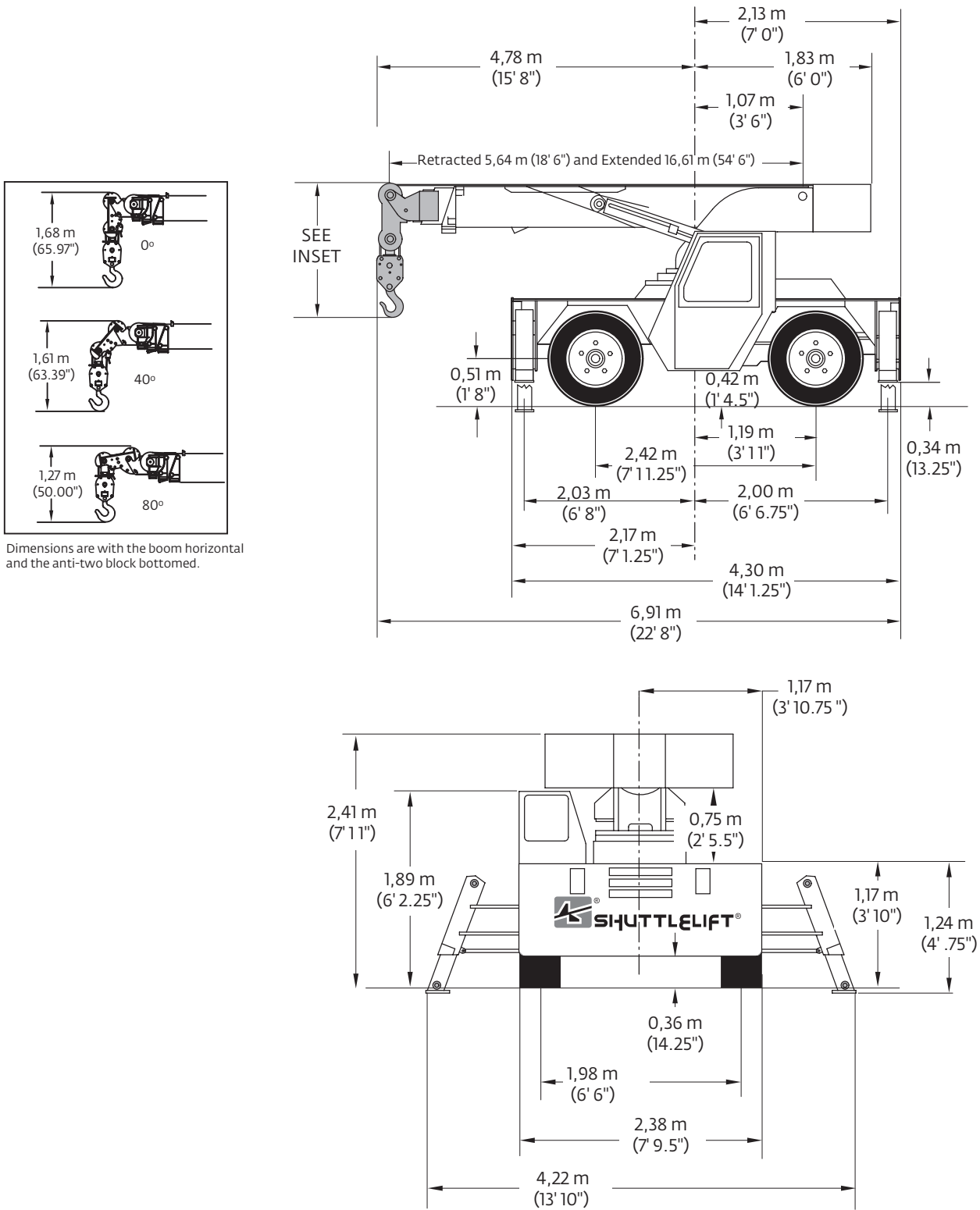

Dimensions are with the boom horizontal and the anti-two block bottomed.

THIS CHART IS ONLY A GUIDE AND SHOULD NOT BE USED TO OPERATE THE CRANE.

The individual crane's load chart, operating instructions and other instructional plates must be read and understood prior to operating the crane.

Range diagram

CD5560B

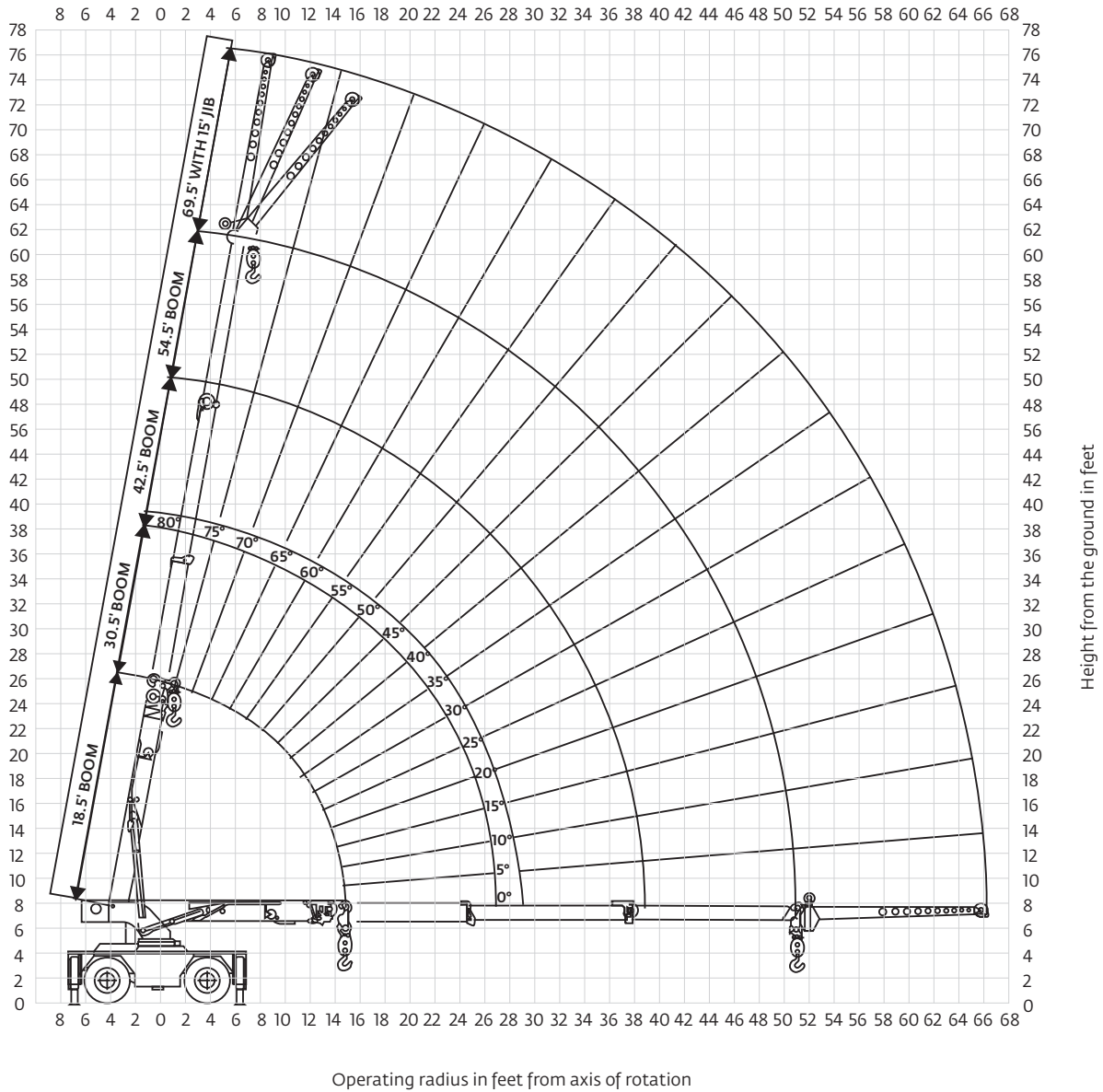

Operating radius in feet from axis of rotation

THIS CHART IS ONLY A GUIDE AND SHOULD NOT BE USED TO OPERATE THE CRANE.

The individual crane's load chart, operating instructions and other instructional plates must be read and understood prior to operating the crane.

Load chart

CD5560B

MAIN BOOM LOAD RATINGS ON OUTRIGGERS Extended and Down 360° or Retracted and Down Front/Rear								
Radius (ft)	18.5 ft BOOM		30.5 ft BOOM		42.5 ft BOOM		54.5 ft BOOM	
	Boom Angle (deg)	Rated Load (lb)	Boom Angle (deg)	Rated Load (lb)	Boom Angle (deg)	Rated Load (lb)	Boom Angle (deg)	Rated Load (lb)
6	64	36,000	75	24,500	79	23,700	-	-
8	57	31,500	71	24,500	77	23,000	80	17,400
10	49	24,000	67	24,000	74	21,500	77	15,800
12	39	19,500	63	20,000	71	19,700	75	14,000
14	25	16,200	58	16,800	68	17,000	73	12,600
15.0	0	15,000	56	15,500	66	15,800	72	12,000
16	-	-	53	14,400	65	14,600	71	11,400
18	-	-	48	12,500	62	12,700	69	10,500
20	-	-	43	11,000	49	11,200	66	9,600
22	-	-	37	9,800	55	10,000	64	8,900
24	-	-	29	8,700	52	9,000	61	8,300
26	-	-	18	7,800	48	8,100	59	7,700
27.0	-	-	0	7,400	6	7,700	58	7,500
28	-	-	-	-	44	7,300	56	7,200
30	-	-	-	-	40	6,500	54	6,700
32	-	-	-	-	36	5,700	51	6,000
34	-	-	-	-	30	5,100	48	5,400
36	-	-	-	-	24	4,500	45	4,800
38	-	-	-	-	15	4,000	42	4,300
39.0	-	-	-	-	0	3,900	41	4,000
40	-	-	-	-	-	-	39	3,800
42	-	-	-	-	-	-	35	3,400
44	-	-	-	-	-	-	31	3,100
46	-	-	-	-	-	-	27	2,900
48	-	-	-	-	-	-	21	2,700
51.0	-	-	-	-	-	-	0	2,400

MAIN BOOM ON RUBBER Any Boom Length		
Radius (ft)	Front Rating (lb)	360° Rating (lb)
6	16,000	10,900
8	13,000	8,700
10	11,000	7,400
12	9,100	6,400
14	7,800	5,600
15.0	7,100	5,300
16	6,500	4,900
18	5,600	4,200
20	4,800	3,500
22	4,200	3,000
24	3,600	2,500
26	3,150	2,200
27.0	2,950	2,050
28	2,800	1,900
30	2,450	1,650
32	2,100	1,400
34	1,900	1,200
36	1,750	1,000
38	1,525	850
39.0	1,450	775
40	1,350	725
42	1,150	625
44	1,050	525
46	950	425
48	850	300
51.0	700	200

NOTES:
JIB CAPACITY IS LIMITED BY BOTH STRUCTURAL CAPACITY CHART AND MAIN CAPACITY CHART.

SHADED AREAS ARE GOVERNED BY STRUCTURAL STRENGTH, DO NOT RELY ON TIPPING.

OPERATION OF THIS EQUIPMENT IN EXCESS OF RATING CHARTS AND DISREGARD OF INSTRUCTIONS IS DANGEROUS AND VOIDS WARRANTY.

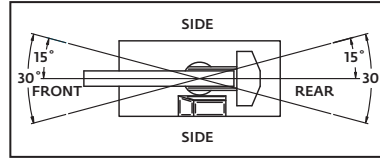

RATING REDUCTIONS FOR LOAD HANDLING DEVICES INSTALLED (lb)		
	FROM MAIN BOOM	FROM JIB
MAIN BLOCK	230	NOT APPLICABLE
HOOK & BALL	100	100
JIB STOWED	NO REDUCTION	NOT APPLICABLE
JIB DEPLOYED	700	NO REDUCTION

MAIN BOOM LOAD RATINGS ON OUTRIGGERS Retracted and Down 360°								
Radius (ft)	18.5 ft BOOM		30.5 ft BOOM		42.5 ft BOOM		54.5 ft BOOM	
	Boom Angle (deg)	Rated Load (lb)	Boom Angle (deg)	Rated Load (lbs)	Boom Angle (deg)	Rated Load (lb)	Boom Angle (deg)	Rated Load (lb)
6	64	36,000	75	24,500	79	23,700	-	-
8	57	29,000	71	24,500	77	23,000	80	17,400
10	49	16,000	67	20,600	74	20,000	77	15,800
12	39	11,400	63	12,900	71	12,800	75	13,000
14	25	8,900	58	9,900	68	10,200	73	10,600
15.0	0	8,000	56	8,900	66	9,300	72	9,500
16	-	-	53	8,100	65	8,500	71	8,500
18	-	-	48	6,800	62	7,200	69	7,200
20	-	-	43	5,900	49	6,200	66	6,100
22	-	-	37	5,000	55	5,200	64	5,300
24	-	-	29	4,100	52	4,500	61	4,500
26	-	-	18	3,600	48	3,800	59	3,900
27.0	-	-	0	3,400	6	3,600	58	3,600
28	-	-	-	-	44	3,300	56	3,300
30	-	-	-	-	40	2,900	54	2,800
32	-	-	-	-	36	2,500	51	2,500
34	-	-	-	-	30	2,200	48	2,200
36	-	-	-	-	24	1,900	45	2,000
38	-	-	-	-	15	1,700	42	1,800
39.0	-	-	-	-	0	1,600	41	1,700
40	-	-	-	-	-	-	39	1,600
42	-	-	-	-	-	-	35	1,400
44	-	-	-	-	-	-	31	1,200
46	-	-	-	-	-	-	27	1,000
48	-	-	-	-	-	-	21	900
51.0	-	-	-	-	-	-	0	700

15 FT JIB CAPACITIES ON EXTENDED OUTRIGGERS					
Main Boom Angle (deg)	Jib Offset Angle				
	0°		15°		30°
	To 42.5 ft Main Boom	To 54.5 ft Main Boom	To 42.5 ft Main Boom	To 54.5 ft Main Boom	Any Boom Length
80	-	-	5000	5000	3500
75	7500	-	4400	4400	3100
70	6100	-	3900	3900	2800
65	5000	4600	3500	3500	2550
60	4300	3800	3150	3150	2350
55	3800	3300	2850	2850	2200
50	3400	2900	2600	2600	2100
45	3050	2600	2400	2400	2000
40	2800	2400	2250	2250	1950
35	2600	2150	2150	2050	1900
30	2400	1930	2080	1850	1830
25	2300	1750	2050	1720	-
20	2200	1600	2000	1590	-
15	2100	1500	1950	1520	-
10	2050	1460	-	-	-
5	2020	1450	-	-	-
0	2000	1440	-	-	-

- The rated loads are the maximum lift capacities as determined by operating radius, boom length and boom angle. The operating radius is the horizontal distance from a projection of the axis of rotation to the supporting surface, before loading, to the center of vertical hoist line or tackle with load applied.
- The rated loads shown on outriggers do not exceed 85% of actual tipping. The rated loads shown on rubber do not exceed 75% of actual tipping. Retracted outrigger rated loads meet ASME B30.5-2004. These ratings are based on freely uniform supporting surface. Practical working loads depend on stability. Hazardous surroundings, climatic conditions, experience account by the operator.
- The weights of all load handling devices, such as hooks, hook blocks, slings, etc, except the hoist rope, shall be considered as part of the load. See above.
- Ratings on outriggers are for either outriggers fully extended and down or fully retracted and down. Ratings for outriggers fully retracted and down will apply for any intermediate outrigger setting.
- Ratings on rubber depend on tire capacity, condition of tires and proper inflation pressure (120 psi). Loads on rubber may be transported at a maximum speed of 2.5 mph on a smooth hard level surface with boom retracted to the shortest length possible and centered over front. Do not use jib with crane on rubber.
- For operating radius not shown, use load rating of next larger radius.
- The maximum combined total boom and deck load is 16,000 lb the maximum deck load only is 20,000 lb.
- Do not induce any external side loads to boom or jib.

80016675

MAXIMUM PERMISSIBLE SINGLE LINE PULL = 9000 LB

WIRE ROPE: 13 mm Diameter 8 X 25 Galvanized
Minimum required breaking strength = 37,200 lb

THIS CHART IS ONLY A GUIDE AND SHOULD NOT BE USED TO OPERATE THE CRANE.

The individual crane's load chart, operating instructions and other instructional plates must be read and understood prior to operating the crane.

Symbols glossary



Axles



Counterweight



Grade



Outriggers



Boom



Drive



Heavy duty jib



Radius



Boom elevation



Electrical system



Hoist



Rotation



Boom extension



Engine



Hookblock



Speed



Boom length



Extension



Hydraulic system



Steering



Boom nose



Frame



Lights



Suspension



Brakes



Fuel tank capacity



Oil



Swing



Cab



Gear



Outrigger controls



Tires



Transmission

Regional Headquarters

Manitowoc - Americas

Manitowoc, Wisconsin, USA

Tel: +1 920 684 6621

Fax: +1 920 683 6277

Shady Grove, Pennsylvania, USA

Tel: +1 717 597 8121

Fax: +1 717 597 4062

Manitowoc - Europe, Middle East & Africa

Ecully, France

Tel: +33 (0)4 72 18 20 20

Fax: +33 (0)4 72 18 20 00

Manitowoc - Asia Pacific

Shanghai, China

Tel: +86 21 6457 0066

Fax: +86 21 6457 4955

Regional Offices

Americas

Brazil

Alphaville

Mexico

Monterrey

Chile

Santiago

Europe, Middle East & Africa

Czech Republic

Netvorice

France

Baudemont

Cergy

Decines

Germany

Langenfeld

Hungary

Budapest

Italy

Parabiago

Netherlands

Breda

Poland

Warsaw

Portugal

Baltar

Russia

Moscow

U.A.E.

Dubai

U.K.

Gawcott

Asia - Pacific

Australia

Brisbane

Melbourne

Sydney

China

Beijing

Xi'an

India

Hyderabad

Pune

Korea

Seoul

Philippines

Makati City

Singapore

Factories

Brazil

Alphaville

China

TaiAn

Zhangjiagang

France

Charlieu

La Clayette

Moulins

Germany

Wilhelmshaven

India

Pune

Italy

Niella Tanaro

Portugal

Baltar

Fânzeres

Slovakia

Saris

USA

Manitowoc

Port Washington

Shady Grove

This document is non-contractual. Constant improvement and engineering progress make it necessary that we reserve the right to make specification, equipment, and price changes without notice. Illustrations shown may include optional equipment and accessories and may not include all standard equipment.

Constant improvement and engineering progress make it necessary that we reserve the right to make specification, equipment and price changes without notice. Illustrations shown may include optional equipment and accessories, and may not include all standard equipment.